



Creating healthy spaces



TC60

Assemblage en montage
Assemblage et montage
Fertigung und Montage
Assembly and installation
Montaje e instalación

Index

1 • Assemblage-instructies	3
2 • Montage-instructies.....	4
2.1 Op glas	4
2.2 Op traverse.....	5
3 • Bedieningsmogelijkheden.....	6
3.1 Stangbediening	6
3.2 Koordbediening	6
4 • Schoonmaak- en onderhoudshandleiding	6

1 • Assemblage-instructies

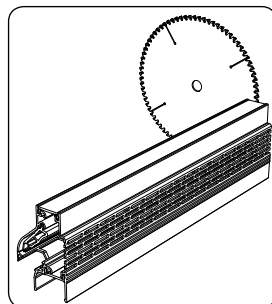
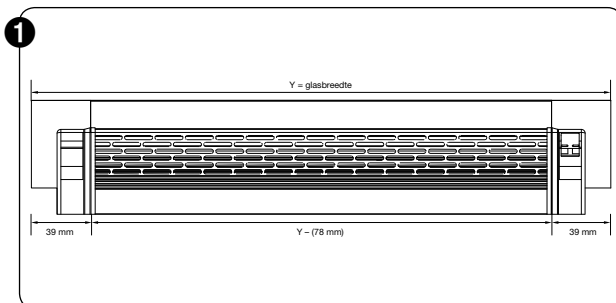

Zagen van TC60: lengte profiel = glasbreedte raam – 78 mm
Gebruik steeds een zaagblad met negatieve tanden!
(zaagblad Ø 400mm / 130 tanden)

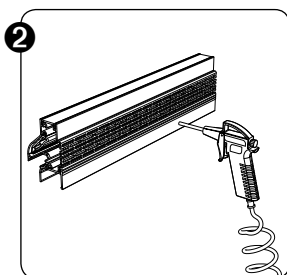

Onderdelen TC60 uit de verpakking halen en met druklucht reinigen.

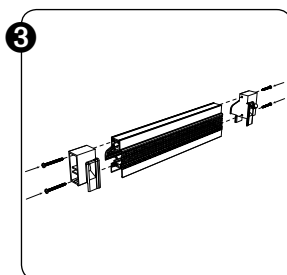

Schroef de kopschotten op de profielen. Gebruik hiervoor de meegeleverde schroeven.

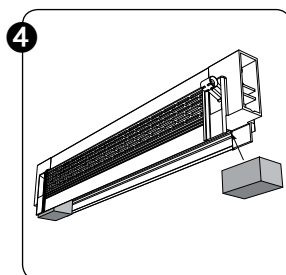

Plaats de afdichtingsmousse op de kopschotten.

2 • Montage-instructies

2.1 • Op glas

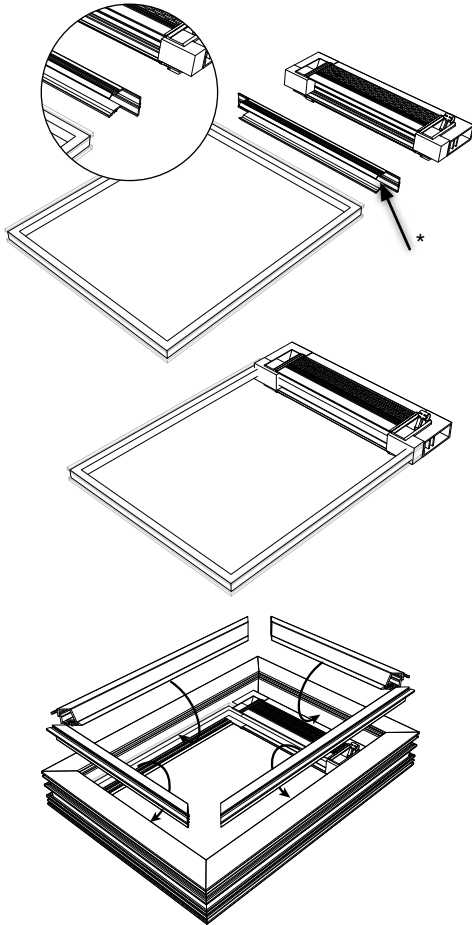

Beglazingsblokjes:
 A: Afstandsblokjes
 B: Steunblokjes

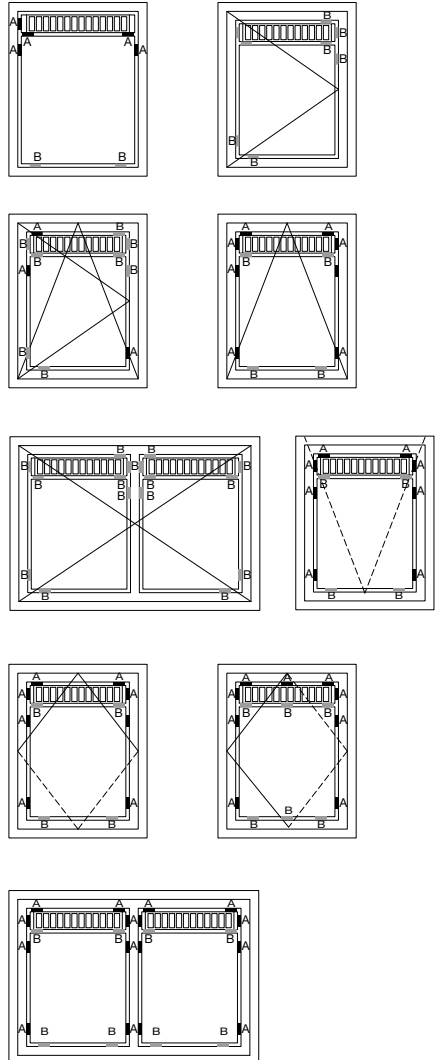

* Droogbeglazingsrubber (Alu, PVC) of
 silicone / compressieband (hout)

A / B:
 Plaatsing: op/onder de kopschotten

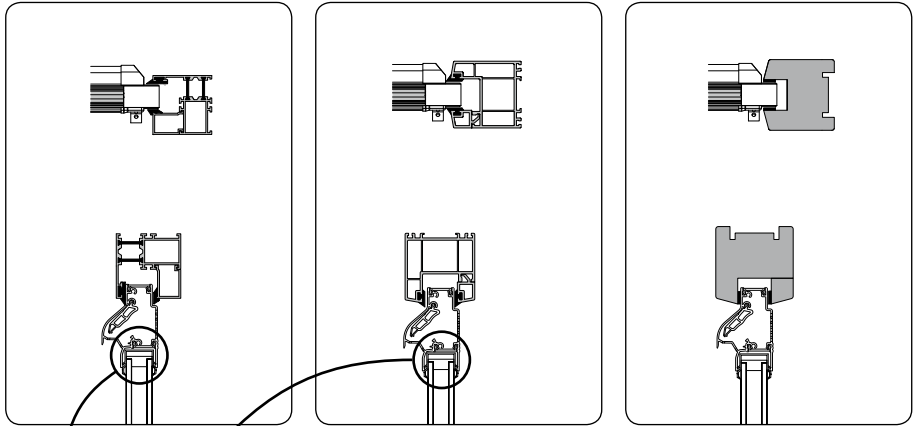

Alu

PVC

Hout

Droogbeglazingsrubber	Kleur	Voor glasdikte
Nr. 029	Zwart	28 – 36 mm
Nr. 034	Grijs	20 – 28 mm
Nr. 039	Zwart	20 – 28 mm

2.2 • Op traverse

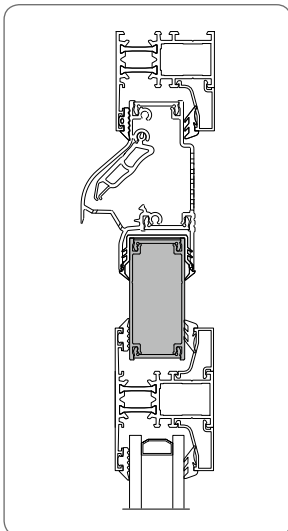

Montage tussen traverse ook mogelijk, mits optioneel traverseprofiel.

Er zijn 2 verschillende traverseprofielen beschikbaar:

- hoogte 35 mm voor aluminium ramen
- hoogte 62 mm voor PVC of houten ramen

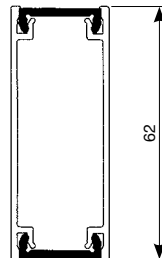
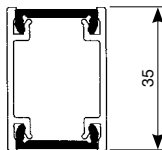

3 • Bedieningsmogelijkheden

3.1 • Stangbediening

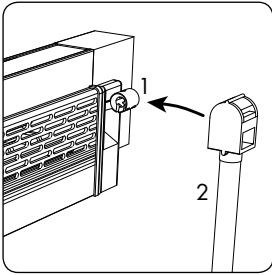

Haak de stang aan de bedieningsclips.

3.2 • Koordbediening

De TC60 kan ook met koordbediening verkregen worden.

OPGELET:

De koordbediening kan niet achteraf geplaatst worden. Gelieve hiermee rekening te houden bij uw bestelling.

4 • Schoonmaak- en onderhoudshandleiding

Reinig de TC60 minimum 1x per jaar.

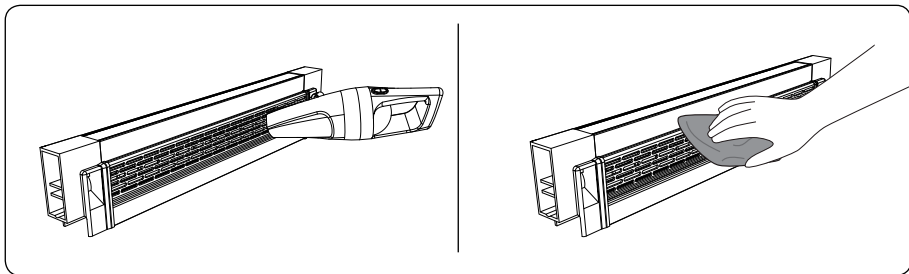

Het rooster reinigen met een stofzuiger, of met een vochtige doek en niet-krassend schoonmaakmiddel. Spoel de met een reinigingsmiddel behandelde TC60 goed na met zuiver water.

Index

1 • Instructions d'assemblage.....	9
2 • Instructions de montage	10
2.1 Sur vitrage	10
2.2 Sur traverse	11
3 • Options de commandes	12
3.1 Commande par tringle.....	12
3.2 Commande par cordelette.....	12
4 • Instructions de nettoyage et d'entretien.....	12

1 • Instructions d'assemblage

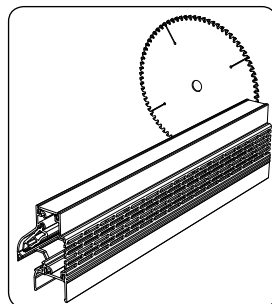
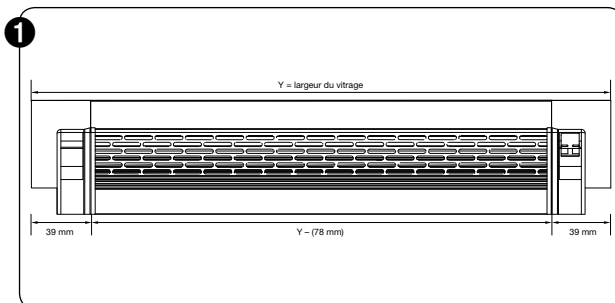

Sciage du profil TC60:

longueur du profil = largeur totale du vitrage – 78 mm.

Utilisez toujours une scie avec des dents négatives!
(Scie Ø 400mm / 130 dents)

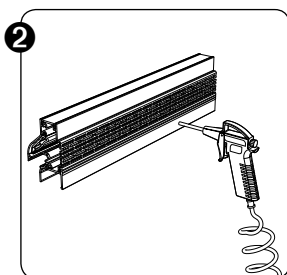

Retirez les éléments du TC60 de l'emballage et nettoyez-les à l'air comprimé.

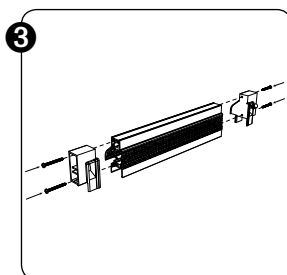

Vissez les embouts sur les profils en aluminium. Utilisez les vis fournies.

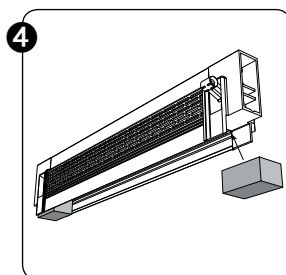

Collez la bande de compression sur les embouts.

2 • Instructions de montage

2.1 • Sur vitrage

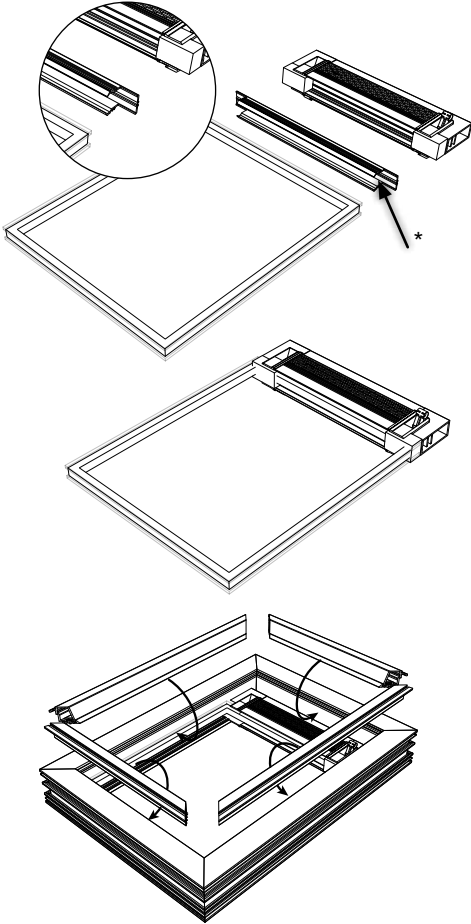

Cales:
 A: Cale de distance
 B: Cale de support

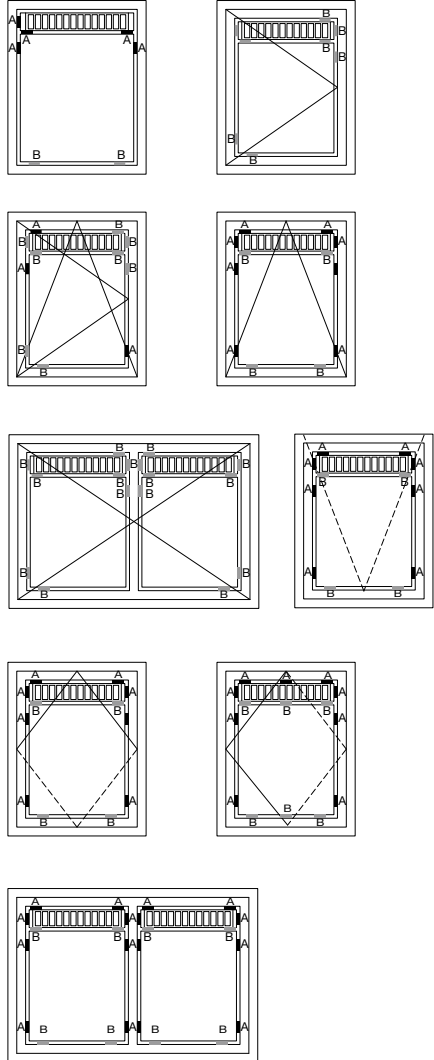

* Joint en caoutchouc (Alu, PVC)
 ou silicone / bande en mousse (bois)

A / B:
 Mise en place: sur/sous les embouts

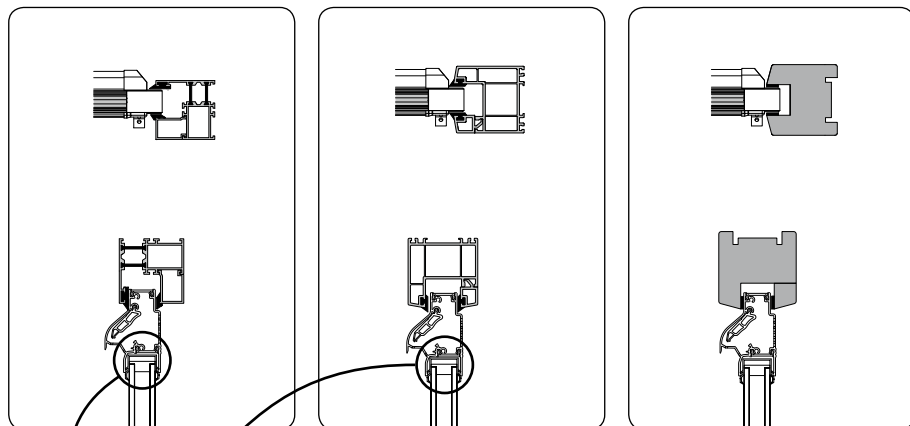

Alu

PVC

Bois

Joint en caoutchouc	Couleur	Pour vitrages d'une épaisseur de
Nr. 029	Noir	28 – 36 mm
Nr. 034	Gris	20 – 28 mm
Nr. 039	Noir	20 – 28 mm

2.2 • Sur traverse

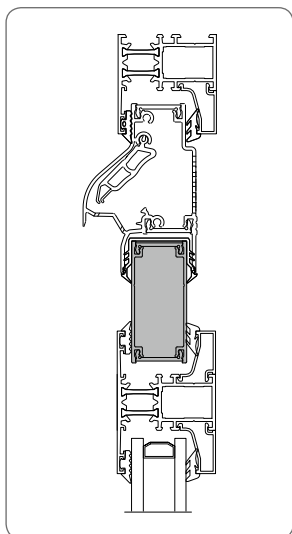

Montage entre traverses aussi possible, moyennant l'utilisation de profils supplémentaires.

Il existe deux modèles de profils de traverse:

- hauteur 35 mm pour des châssis en aluminium
- hauteur 62 mm pour des châssis en PVC ou bois.

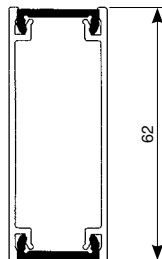
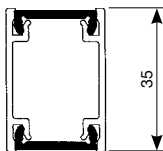

3 • Options de commandes

3.1 • Commande par tringle

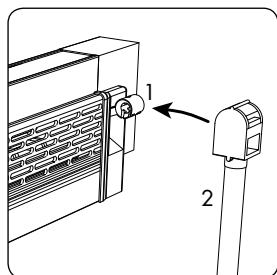

Accrochez la tringle sur le clips de commande.

3.2 • Commande par cordelette

Le TC60 est aussi disponible avec commande par cordelette.

Faites attention:

La commande par cordelette ne peut pas être ajoutée après.
Veuillez en tenir compte lors de votre commande.

4 • Instructions de nettoyage et d'entretien

L'entretien du TC60 doit être réalisé au moins 1 fois par an.

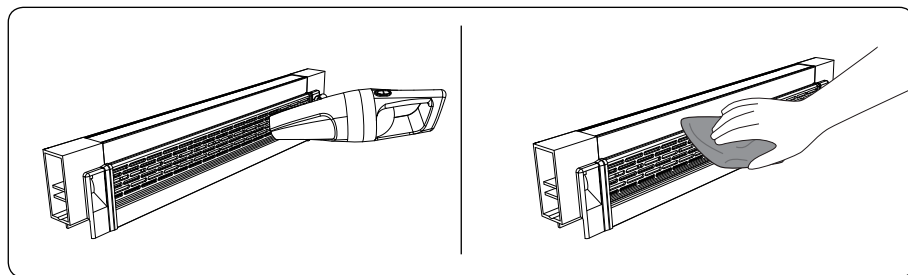

Nettoyez la grille à l'aspirateur ou avec un chiffon humide et des produits d'entretien neutres non-abrasifs. Rincez bien le TC60 à l'eau claire après l'avoir nettoyé avec un produit d'entretien.

Index

1 • Fertigungsanleitung	15
2 • Montage-richtlinie	16
2.1 Auf Glas	16
2.2 Im Blendrahmen	17
3 • Steuerungsoptionen	18
3.1 Gestänge	18
3.2 Zugschnurbetätigung	18
4 • Reinigungs- und Wartungsanleitung	18

1 • Fertigungsanleitung

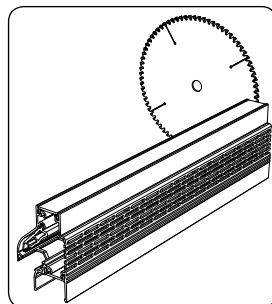
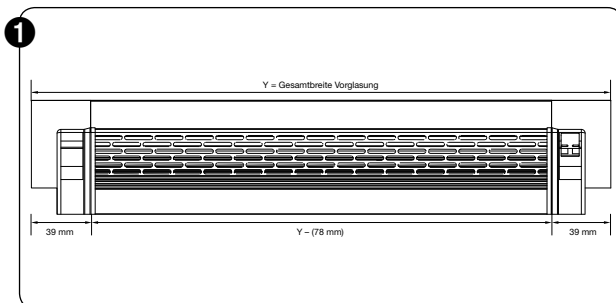

Zusügen des Profils des TC60: Länge Profil = Gesamtbreite Verglasung - 78 mm
Beim Sägen immer ein Sägeblatt mit negativen Schnittwinkelzähnen anwenden! (Sägeblatt Ø 400mm / 130 Zähne)

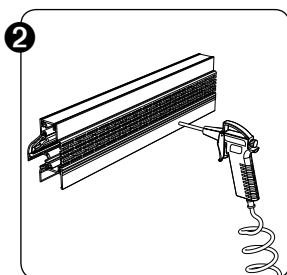

2 Nehmen Sie die Komponenten des TC60 aus der Verpackung und reinigen Sie sie mit Druckluft.

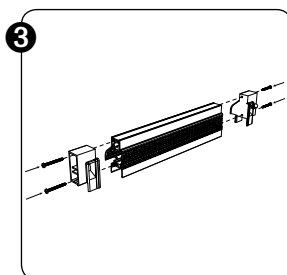

3 Schrauben Sie die Endkappen auf die Profile. Verwenden Sie hierfür die mitgelieferten Schrauben.

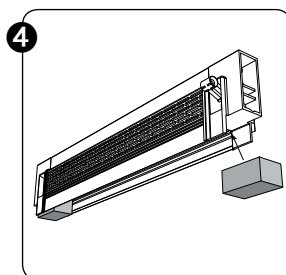

4 Montieren Sie die Schaumstoffdichtung unten die Endkappe.

2 • Montage-richtlinie

2.1 • Auf glas

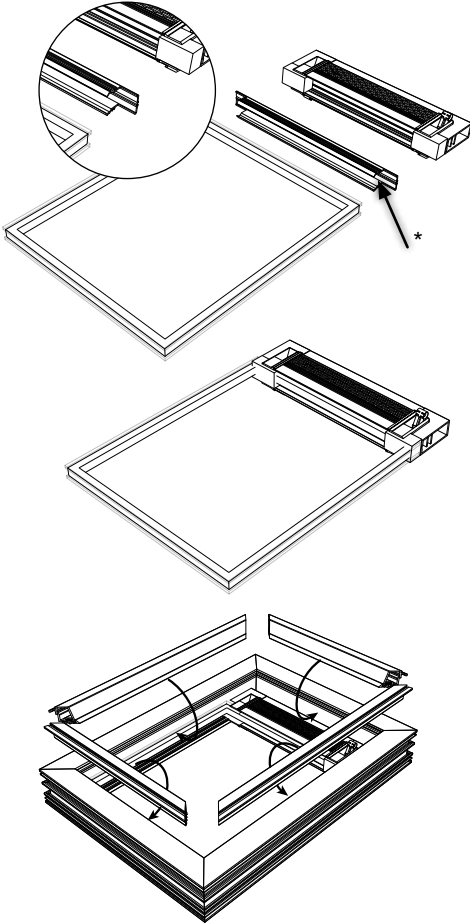

Verglasungsklötze:

A: Distanzklötze

B: Tragklötze

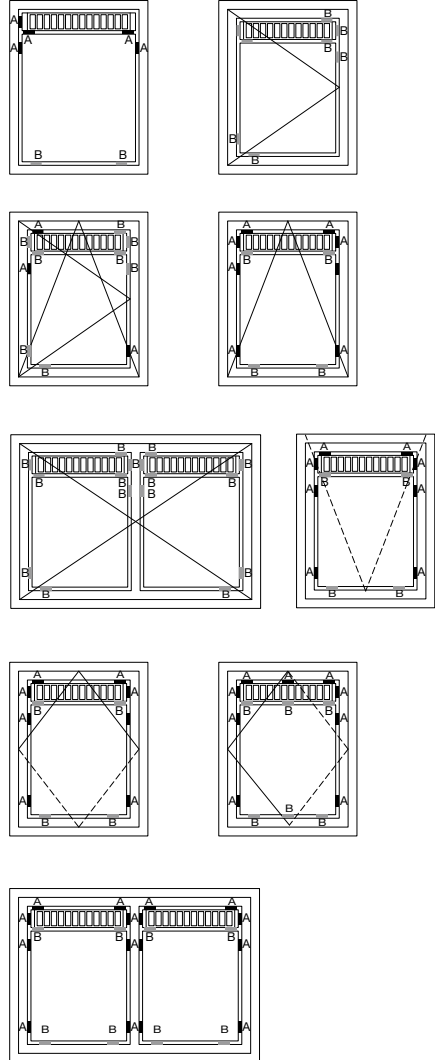

* Trockenverglasungsdichtung (Alu, PVC)
oder Silikon / Dichtungsband (Holz)

A / B:
Montage: Auf/unter die Endkappe

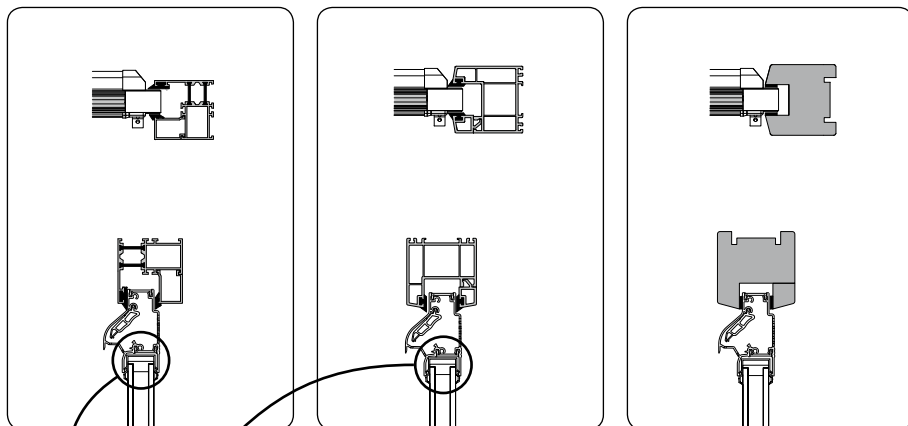

Alu

PVC

Holz

Trockenverglasungsdichtung	Farbe	Für Glasstärken
Nr. 029	Schwarz	28 – 36 mm
Nr. 034	Grau	20 – 28 mm
Nr. 039	Schwarz	20 – 28 mm

2.2 • Im Blendrahmen

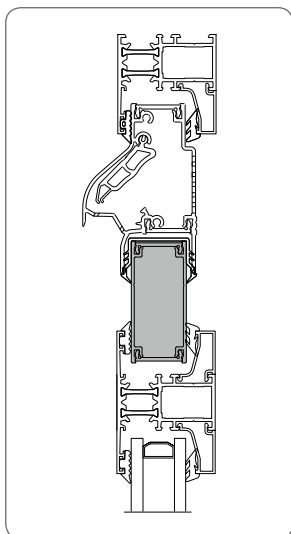

Blendrahmeneinbau auch möglich, mithilfe eines zusätzlichen Blendrahmenprofils.

Zwei verschiedene Blendrahmen profile sind erhältlich:

- Höhe 35 mm für Fenster aus Aluminium
- Höhe 62 mm für Fenster aus PVC oder Holz

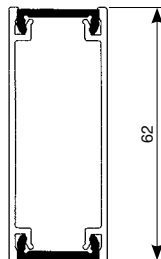
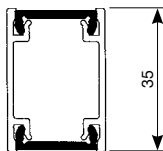

3 • Steuerungsoptionen

3.1 • Gestänge

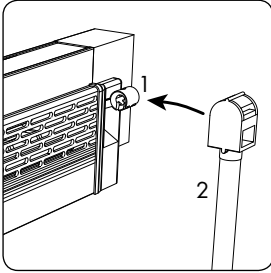

Haken Sie das Gestänge ein.

3.2 • Zugschnurbetätigung

Die TC60 kann mit Zugschnurbetätigung erreicht werden.

BITTE BEACHTEN SIE:

Die Zugschnurbetätigung kann nicht nachgerüstet werden.
Bitte bedenken Sie dies bei Ihrer Bestellung.

4 • Reinigungs- und Wartungsanleitung

Reinigen Sie den TC60 mindestens einmal jährlich.

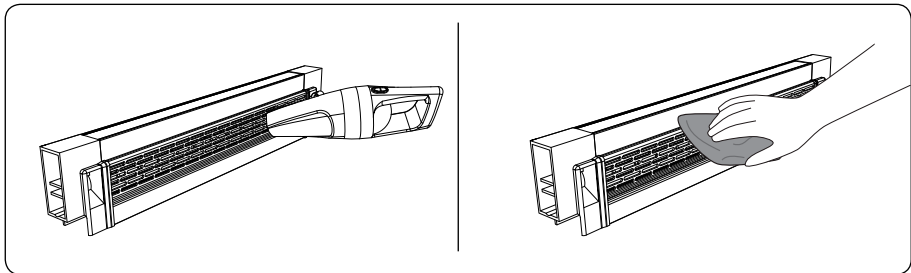

Reinigen Sie das Gitter mit einem Staubsauger oder einem feuchten Tuch und nicht scheurendem Reinigungsmittel. Spülen Sie die mit einem Reinigungsmittel behandelten TC60 gründlich mit klarem Wasser nach.

Index

1 • Assembly instructions	21
2 • Installation instructions	22
2.1 Glazed-in	22
2.2 At transom	23
3 • Control options	24
3.1 Rod control	24
3.2 Cord control	24
4 • Cleaning and maintenance instructions	24

1 • Assembly instructions

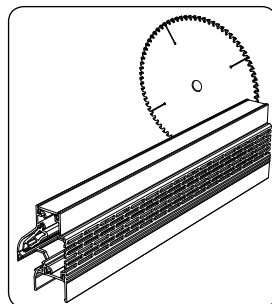
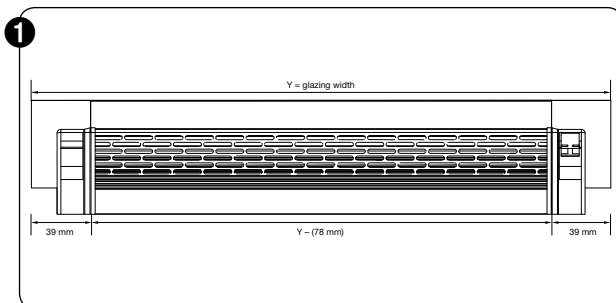

Profile cutting TC60: profile length = overall glazing width - 78mm
Always use a cutting blade with negative tooth angle!
(cutting blade Ø 400mm / 130 teeth)

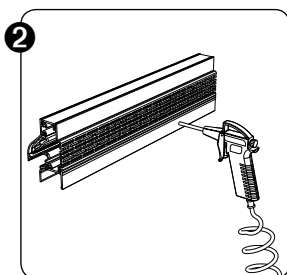

Unpack the TC60 components, and clean them using compressed air.

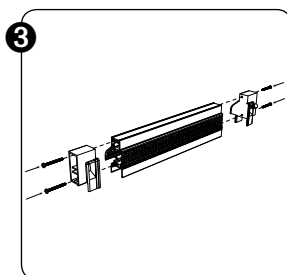

Screw the end caps onto the aluminium profiles. Use the screws supplied for this.

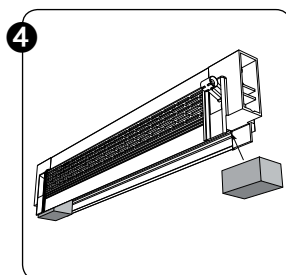

Place the foam sealant on the endcaps.

2 • Installation instructions

2.1 • Glazed-in

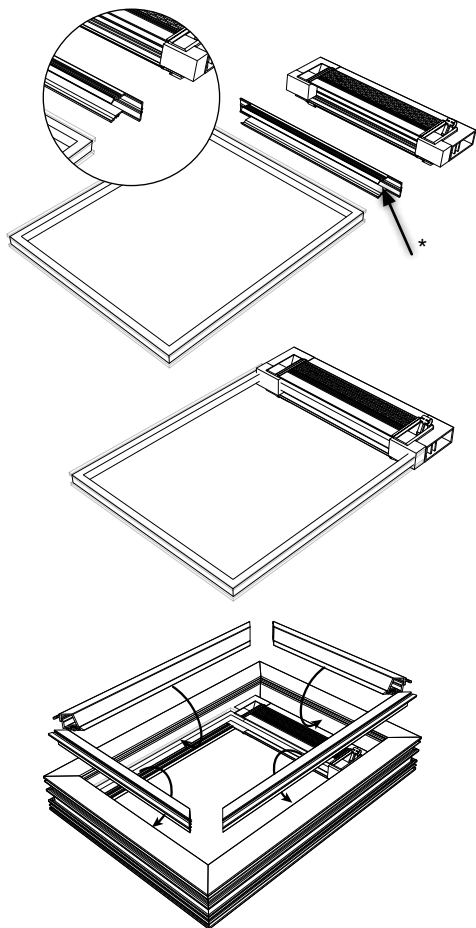

* Glazing gaskets (Alu, uPVC)
or silicone / foam tape (wood)

Glazing blocks:
A: Distance blocks
B: Setting blocks

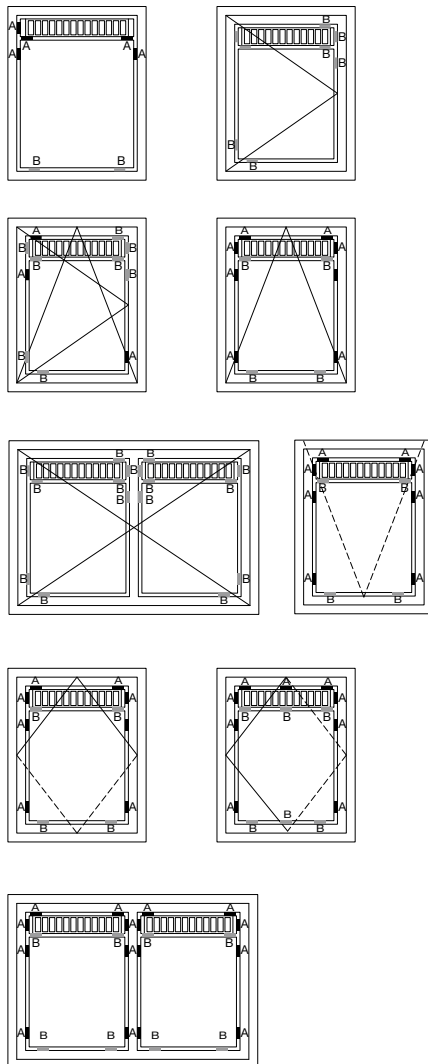

A / B:
Positioning: On/under the endcaps

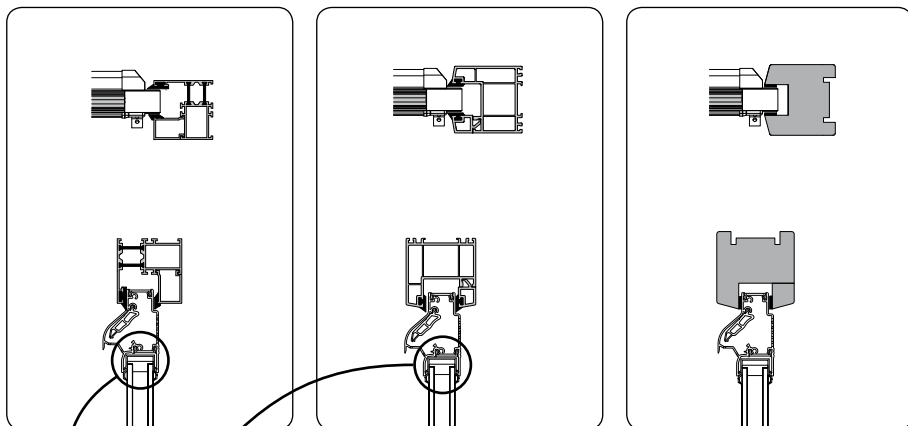

Alu

uPVC

Wood

Glazing gaskets	Colour	For glass thickness
Nr. 029	Black	28 – 36 mm
Nr. 034	Grey	20 – 28 mm
Nr. 039	Black	20 – 28 mm

2.2 • At transom

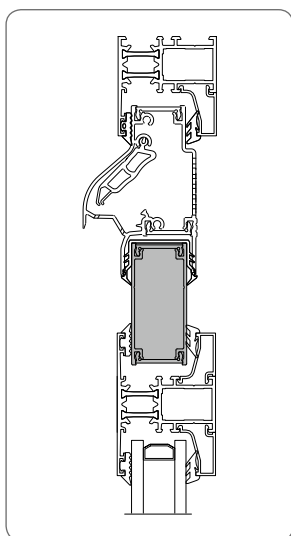

Installation between profiles (at transom) also possible, using the optional transom profile.

Two different transom profiles are available:

- height 35 mm for aluminium window profiles
- height 62 mm for uPVC or wood window profiles

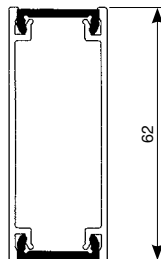
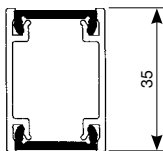

3 • Control options

3.1 • Rod control

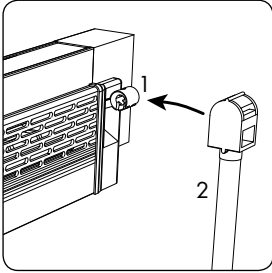

Latch the rod on the control clip.

3.2 • Cord control

The TC60 is also available with cord control.

ATTENTION:

Please bear in mind that the cord control can not be installed afterwards.
Please consider this when ordering.

4 • Cleaning and maintenance instructions

Maintenance must be performed at least once a year.

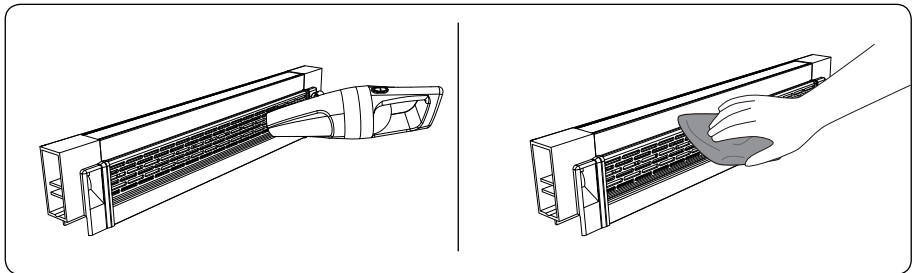

Clean the grille by using a vacuum cleaner or a damp cloth and a non-abrasive cleaner.
Rinse the TC60 thoroughly with clean water.

Index

1 • Instrucciones de ensamblaje	27
2 • Instrucciones de montaje	28
2.1 Instalación en cristalera	28
2.2 Instalación en dintel	29
3 • Opciones de control	30
3.1 Por varilla	30
3.2 Por cordón	30
4 • Instrucciones de limpieza y mantenimiento	30

1 • Instrucciones de ensamblaje

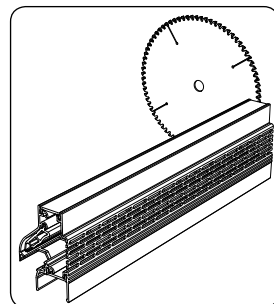
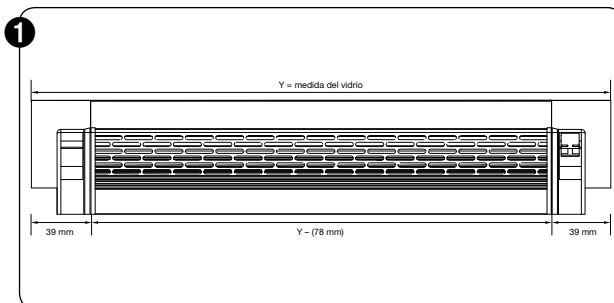

Cortar el perfil TC60: longitud del perfil = medida del vidrio - 78 mm
Siempre utilicen una sierra con dientes negativos!
(Sierra Ø 400mm / 130 dientes)

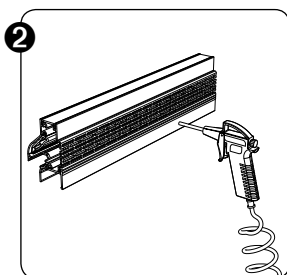

2 Saquen los componentes del TC60 del embalaje y límpienlos con aire comprimido.

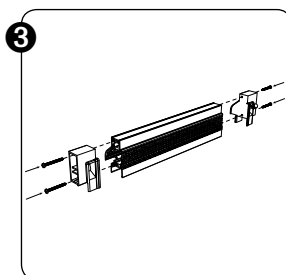

3 Atornillen las tapas laterales en los perfiles. Utilicen los tornillos suministrados.

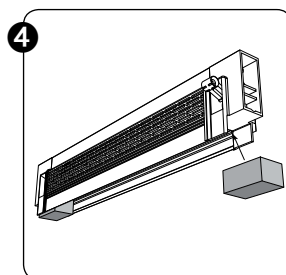

4 Pongan la junta de espuma en las tapas laterales.

2 • Instrucciones de montaje

2.1 • Instalación en cristalera

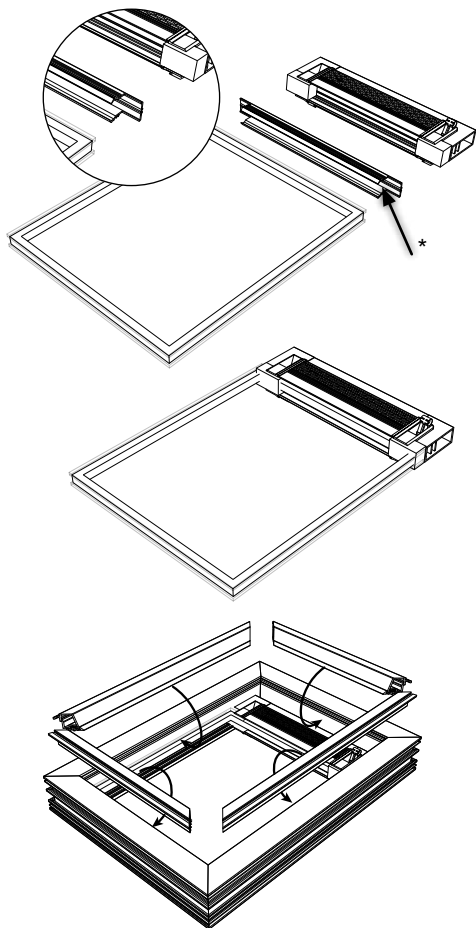

* Junta de acristamiento (Alu, PVC)
o silicona / cinta de aspuma (Madera)

Piezas de acristamiento:

A: Pieza de distancia

B: Pieza de soporte

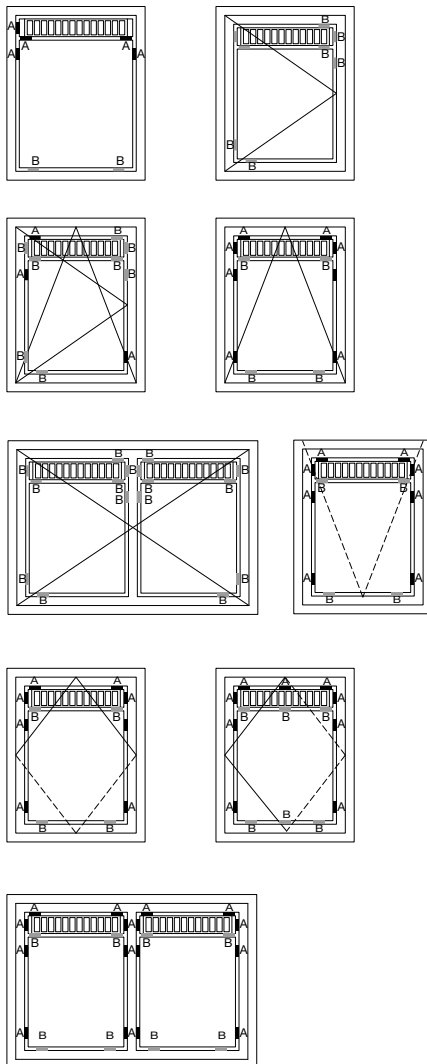

A / B:

Colocación: encima o debajo de las tapas

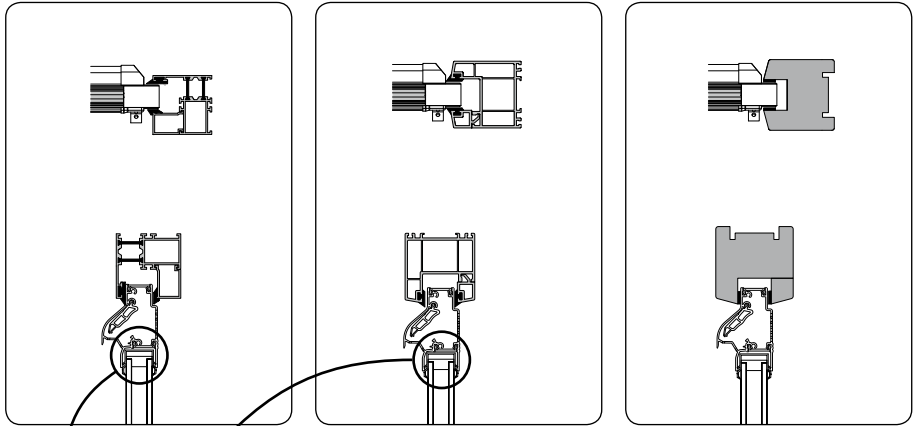

Alu

PVC

Madera

Junta de acristalamiento	Color	Para anchura de vidrio
Nr. 029	Negro	28 – 36 mm
Nr. 034	Gris	20 – 28 mm
Nr. 039	Nigro	20 – 28 mm

2.2 • Instalación en dintel

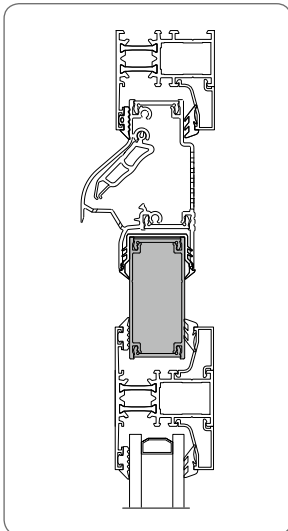

Colocación en dintel posible, con perfil opcional.

Existen dos perfiles diferentes para dinteles:

- 35 mm de altura : aluminium
- 62 mm de altura : PVC / madera

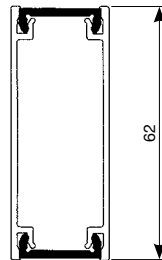
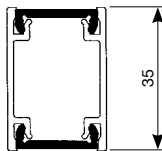

3 • Opciones de control

3.1 • Por varilla

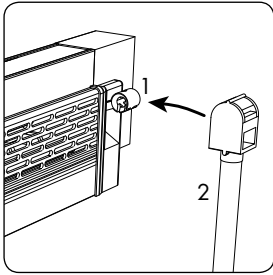

Enganchen la carilla.

3.2 • Por cordón

El TC60 también está disponible con control por cordón.

SIN EMBARGO:

no se puede añadir el cordón después.
Por favor, tengan en cuenta esta observación al hacer un pedido.

4 • Instrucciones de limpieza y mantenimiento

Limpie el aireador TC60 una vez al año, como mínimo.

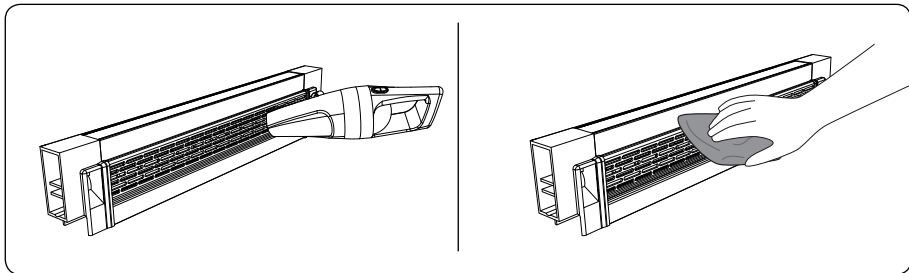

Limpie la rejilla con una aspiradora o con un paño húmedo y productos de limpieza neutros no abrasivos. Enjuaguen bien el aireador TC60 con agua limpia después de haberlo lavado con un producto de limpieza.



Creating healthy spaces

RENSON®: your partner in ventilation and sun protection

RENSON®, headquartered in Waregem (Belgium), is a trendsetter in Europe in natural ventilation and sun protection.

- **Creating healthy spaces**

From 1909, we've been developing energy efficient solutions assuring a healthy and comfortable indoor climate.

Our remarkable headquarters - built according to the 'Healthy Building Concept' - is a beautiful example portraying our corporate mission.

- **No speed limit on innovation**

A multidisciplinary team of more than 40 R&D employees continually optimize our products and develop new and innovative concepts.

- **Strong in communication**

Contact with the customer is of the utmost importance. A group of 65 in-the-field employees worldwide and a powerful international distribution network are ready to advise you on site. The RENSON® Experience Center at Waregem gives you the possibility to experience our products on your own and provides necessary training for installers.

- **A reliable partner in business**

We can guarantee our customers optimal quality and service thanks to our environmentally friendly and modern production sites (with automated powder coating line, anodisation line, uPVC injection molding machinery and mold making shop) covering an area of 75.000 m².

Dealer



RENSON® reserves the right to make technical changes to the products shown. The most recent versions of our brochures can be downloaded from www.renson.eu

N.V. RENSON® Ventilation S.A • Maalbeekstraat 10 • IZ 2 Vijverdam • B-8790 Waregem
Tel. +32 (0)56 62 71 11 • Fax +32 (0)56 60 28 51 • ventilation@renson.be • www.renson.eu

